

COVER SHEET		
ELEVATION TYPES	_____	ENT-1
ELEVATION TYPES	_____	ENT-2
ELEVATION TYPES	_____	ENT-3
ELEVATION TYPES	_____	ENT-4
ELEVATION TYPES (SLIDING ENTRANCE)	_____	ENT-5
ELEVATION TYPES (BI-FOLDING ENTRANCE)	_____	ENT-6
SECTION DETAILS	_____	ENT-7
SECTION DETAILS	_____	ENT-8
SPECIFICATIONS:	STILE & RAIL	
	STAINLESS STEEL	
	BRONZE	

## ENTRANCES

## STANDARD STILE & RAIL SYSTEM

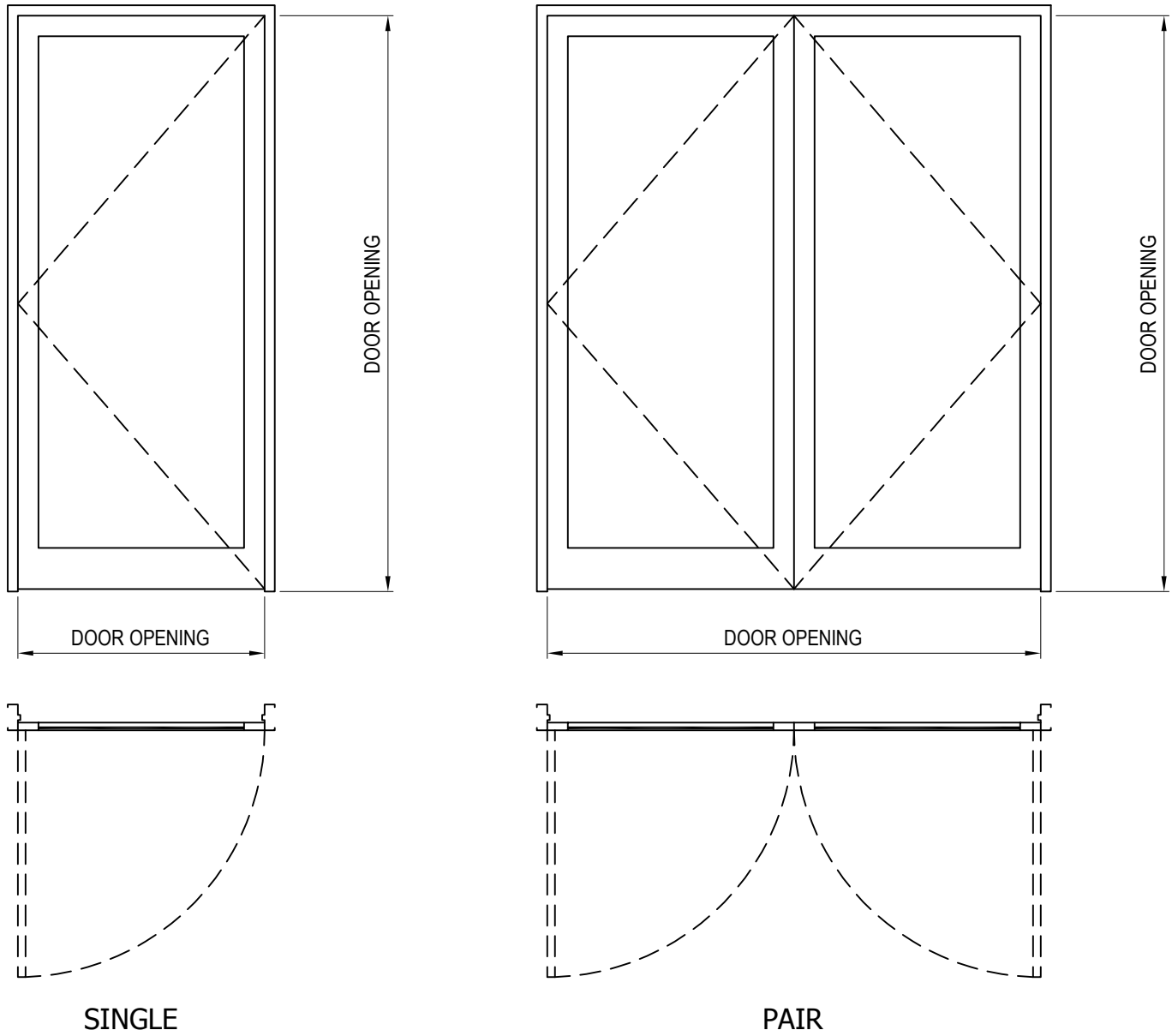

### DESIGN FEATURES:

UNRESTRICTED PROFILE AND SIZES

PREFINISHED GALVANIZED STEEL, STAINLESS STEEL  
AND BRONZE

ALL MORTISE HARDWARE PREPS ARE TO BE DONE  
BY THE MANUFACTURER, ALL SURFACE MOUNTED  
PREPS ARE TO BE DONE BY THE INSTALLER

ENTRANCES

## STILE & RAIL WITH MID-RAIL SYSTEM

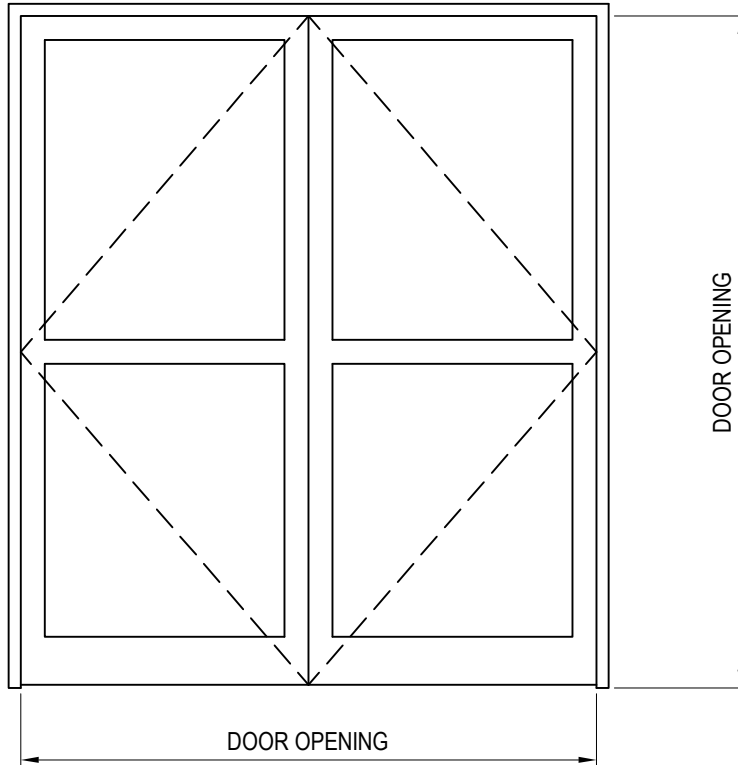

## STILE & RAIL WITH MULTIPLE LITES SYSTEM

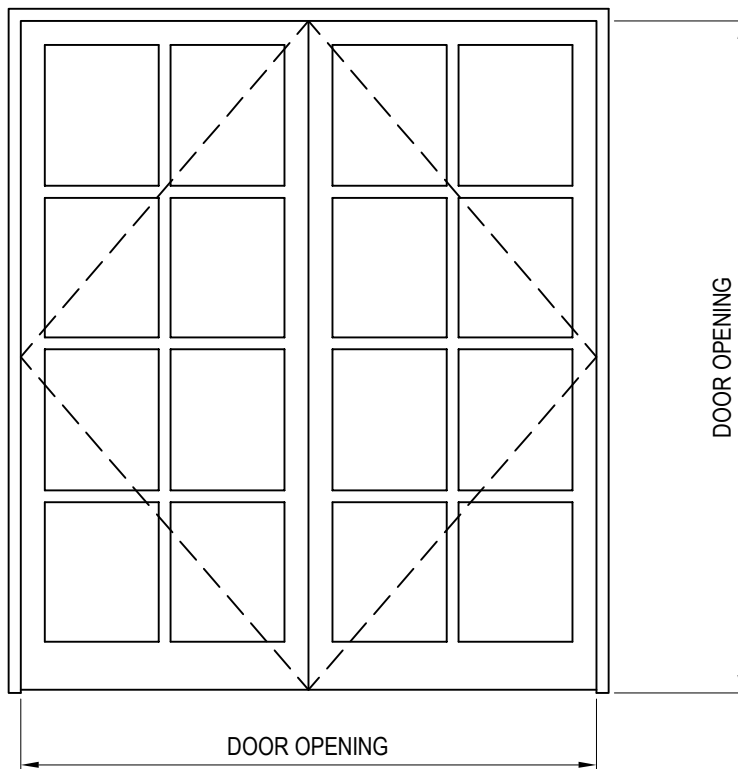

## ENTRANCES

STILE & RAIL WITH RADIUS TOP SYSTEM

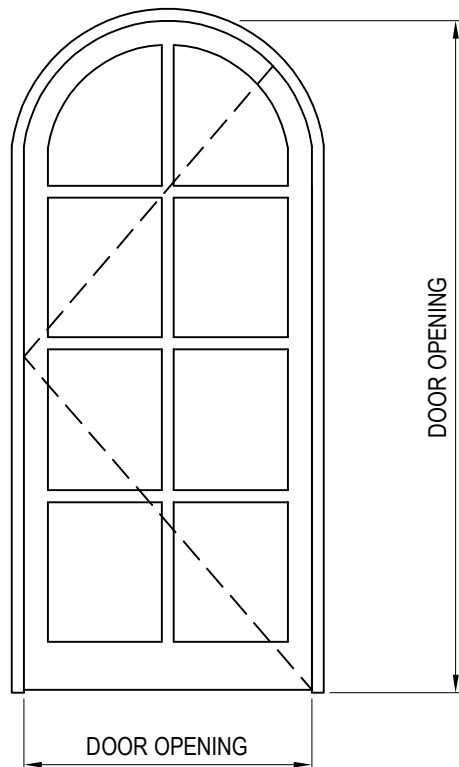

STILE & RAIL WITH RADIUS TOP SYSTEM

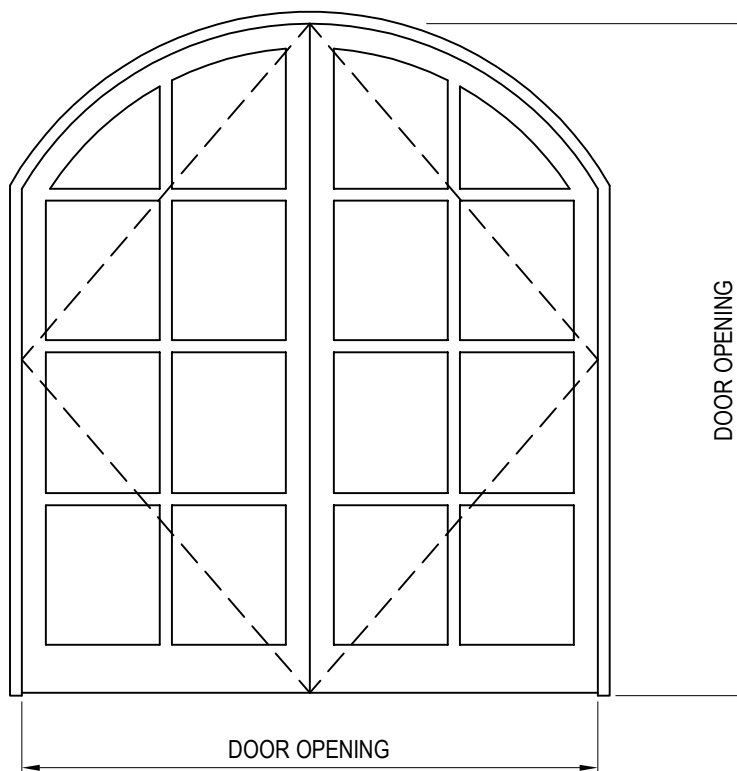

ENTRANCES

## FLUSH DOOR SYSTEM

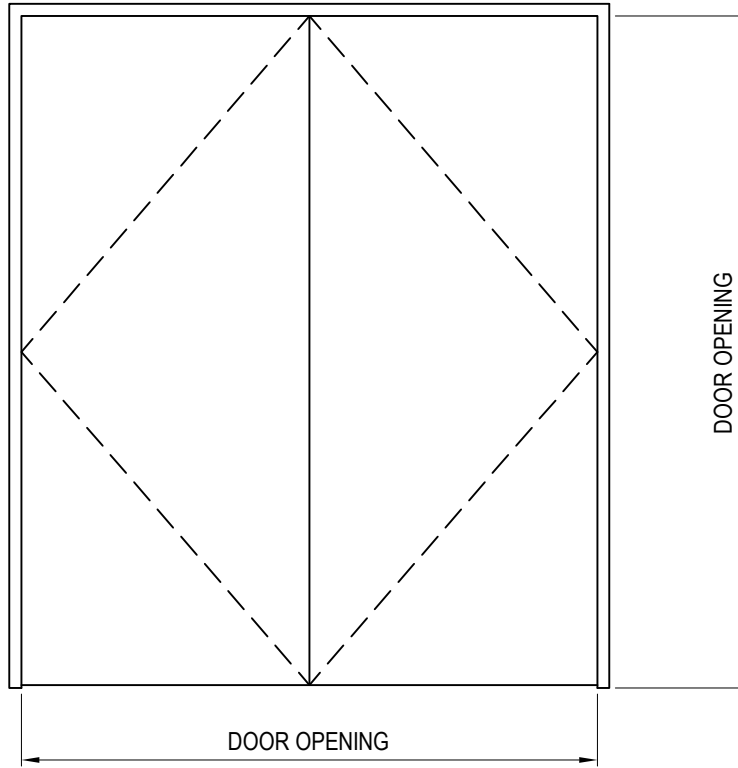

## PANEL DOOR SYSTEM

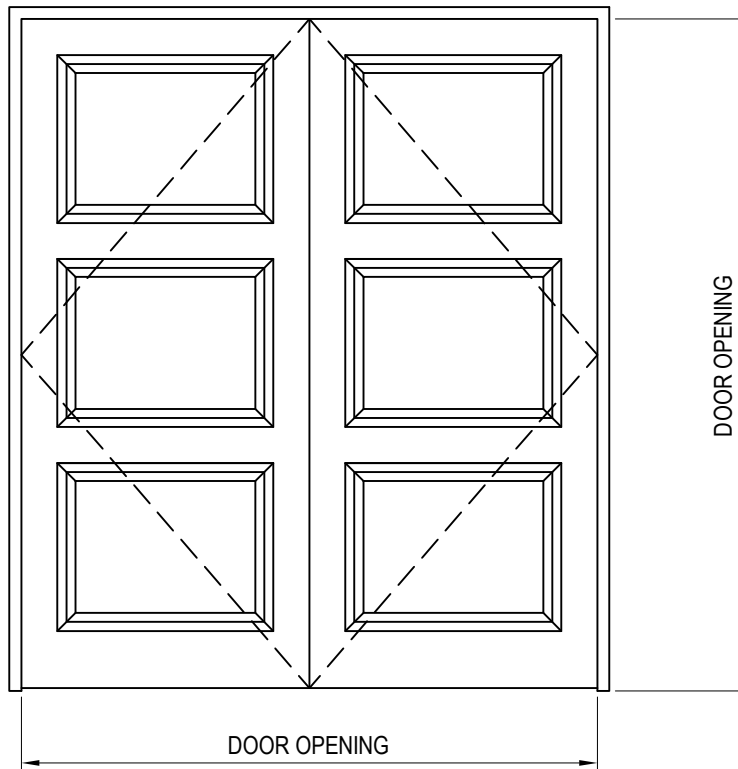

## ENTRANCES

## SLIDING ENTRANCE SYSTEM

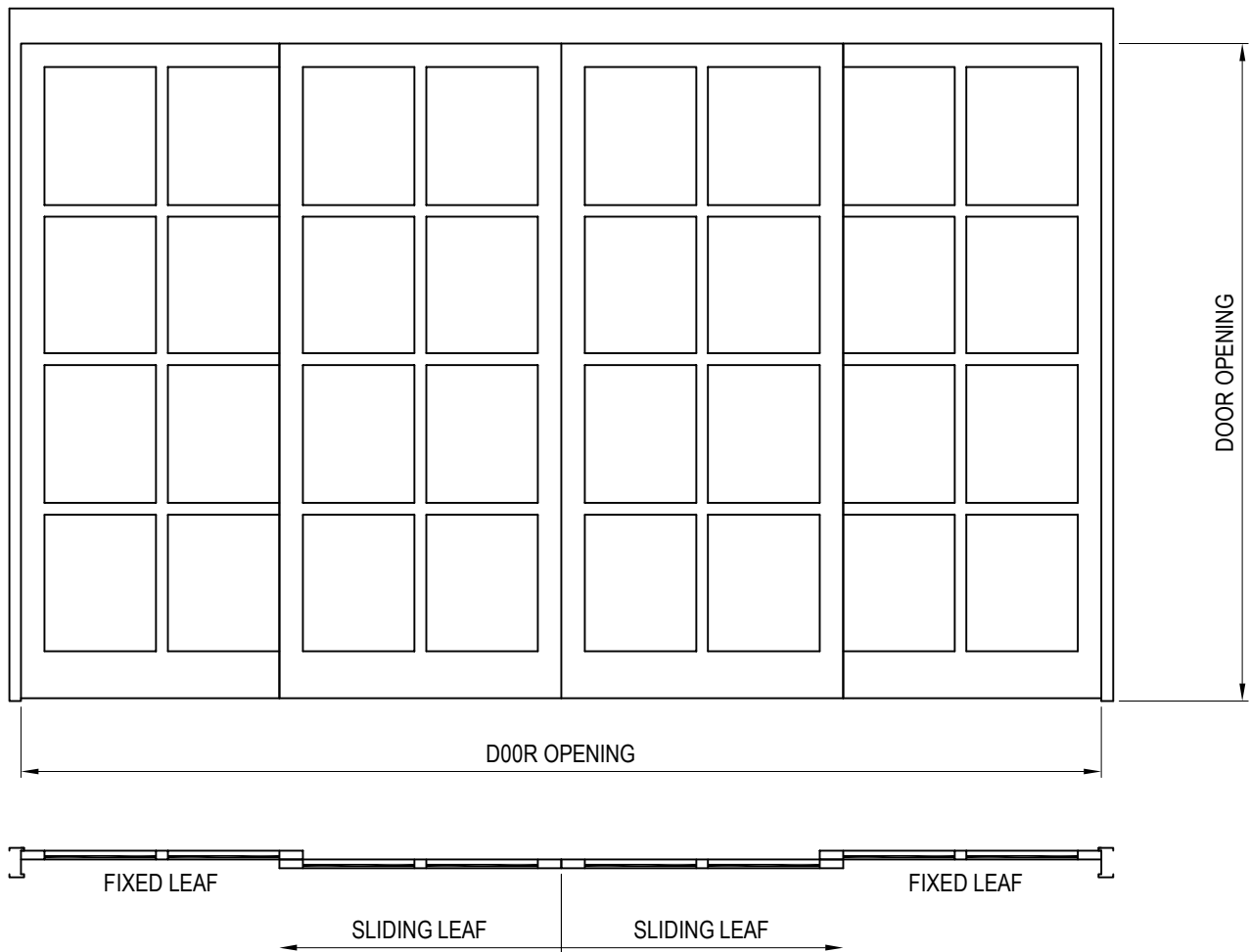

### DESIGN FEATURES:

UNRESTRICTED PROFILE AND SIZES

PREFINISHED GALVANIZED STEEL, STAINLESS STEEL  
AND BRONZE

SLIDING ENTRANCES INCLUDE  
THE FOLLOWING HARDWARE:

1. TOP TRACK WITH ROLLER (IF TOP HUNG)
2. BOTTOM TRACK WITH ROLLERS (IF BOTTOM LOAD)
3. GUIDE TRACKS (TOP OR BOTTOM)
4. LATCHING LOCK SYSTEM WITH HANDLE
5. SURFACE MOUNTED WEATHERSTRIP

## ENTRANCES

## BI-FOLDING ENTRANCE SYSTEM

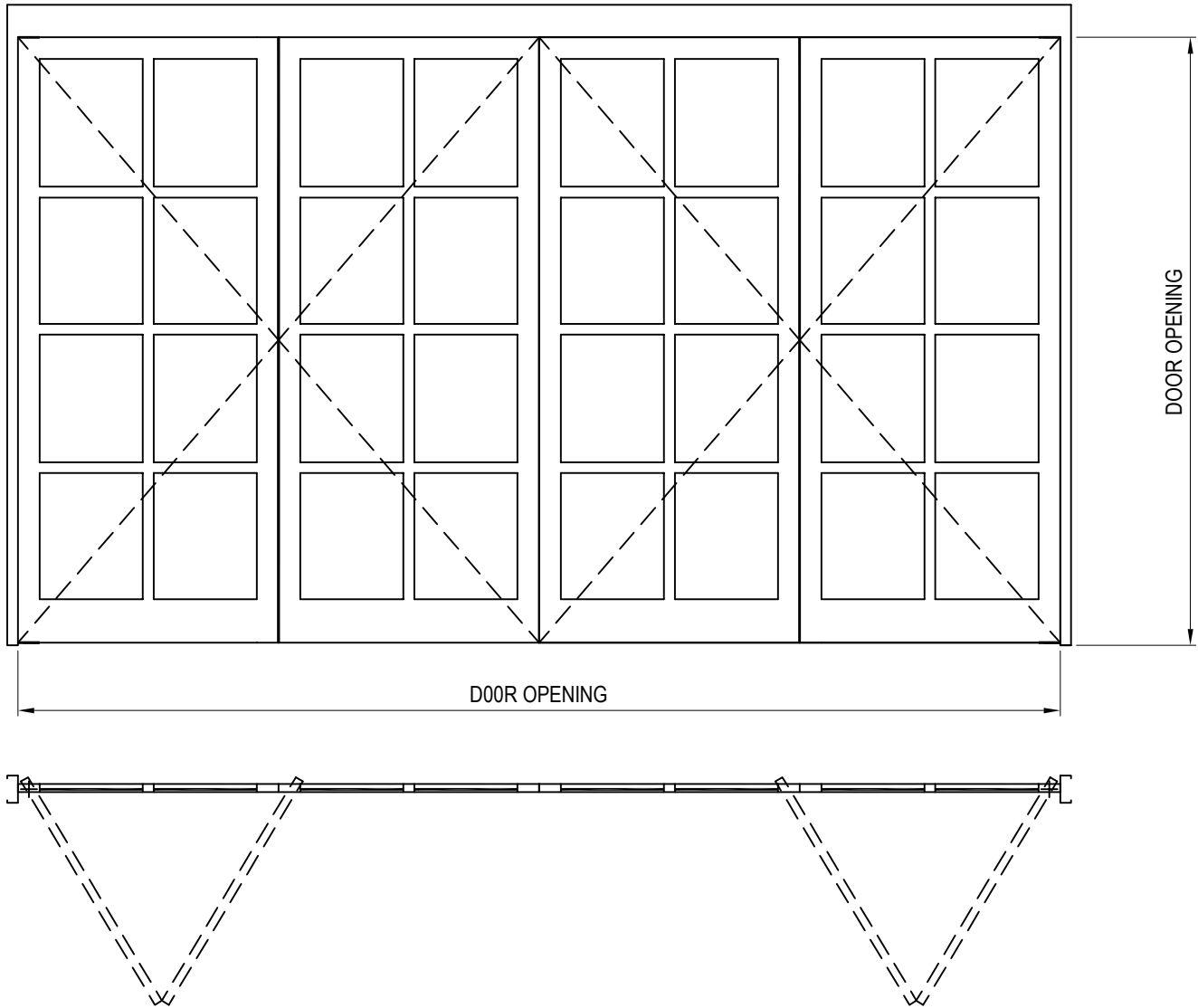

### DESIGN FEATURES:

UNRESTRICTED PROFILE AND SIZES

PREFINISHED GALVANIZED STEEL, STAINLESS STEEL  
AND BRONZE

BI-FOLDING ENTRANCES INCLUDE  
THE FOLLOWING HARDWARE:

1. TOP & BOTTOM PIVOTS
2. TOP TRACK WITH HANGERS
3. BOTTOM GUIDE
4. CONTINUOUS HINGES
5. LOCKING DEVICE
6. SURFACE MOUNTED FLUSH BOLTS
5. SURFACE MOUNTED WEATHERSTRIP

ENTRANCES

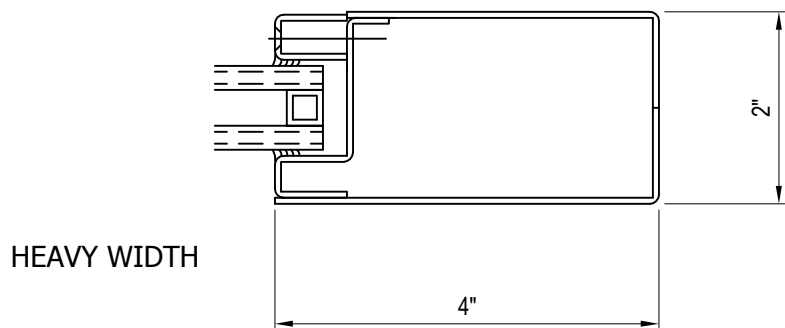
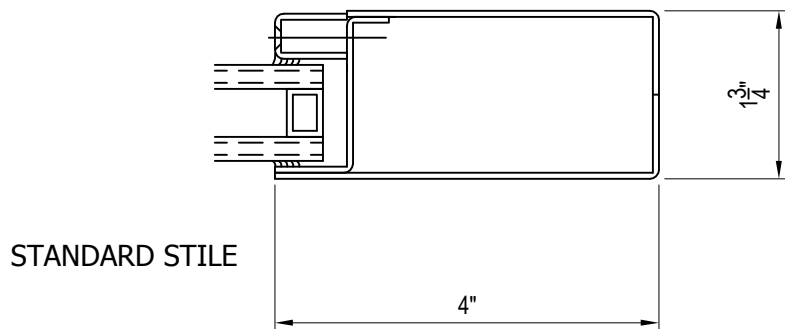
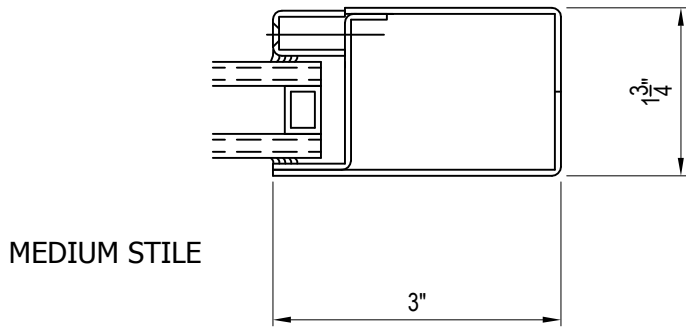
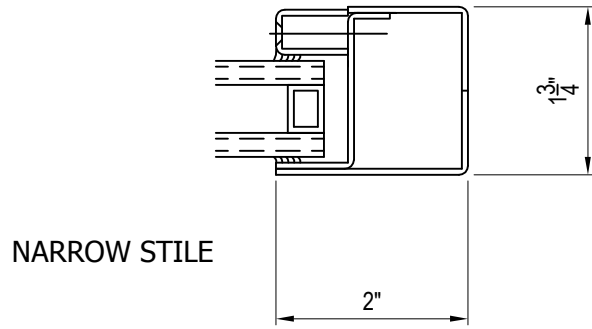

ENTRANCES

SECTION DETAIL



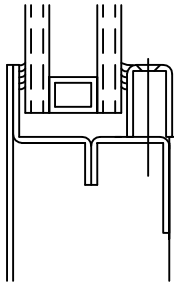

1" INSULATED GLASS  
WITH SCREWED-ON STOP

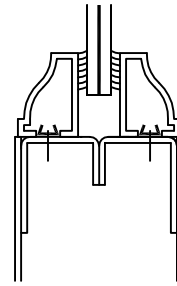

1/4" THK. GLASS  
WITH DECORATIVE STOPS

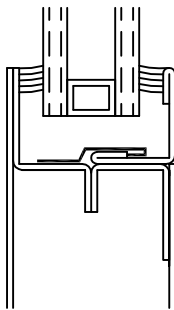

1" INSULATED GLASS  
WITH SNAP-ON STOP

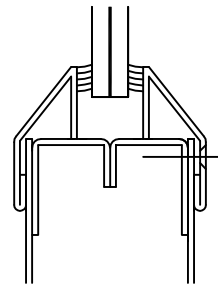

STANDARD GLASS  
WITH SLOPED VISION FRAME

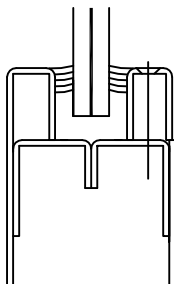

STANDARD GLASS  
WITH SCREWED-ON STOP

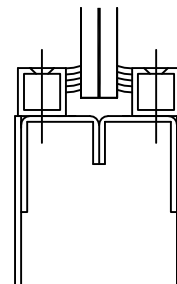

STANDARD GLASS  
WITH TUBE STOPS

ENTRANCES

SECTION DETAIL

**TRUE STYLE AND RAIL STEEL DOORS AND FRAMES  
SECTION 081110**

**PART I GENERAL**

**1.01 SUMMARY:**

- A. Description: This section includes Steel Doors, Frames, Sidelights, Transom and Window Frames where shown on the drawings and as specified here in.
- B. Related work not included in this section:
  - 1. Builders Finish Hardware including Gaskets and Weather-stripping
  - 2. Glass and glazing.
  - 3. Sealant and Caulking at Joints

**1.02 QUALITY ASSURANCE:**

- A. Applicable standards of the following as referenced herein:
  - 1. AAMA, American Architectural Manufacturers Association.
  - 2. ANSI, American National Standards Institute.
  - 3. ASTM, American Society for Testing and Materials.
  - 4. ADA, Americans with Disabilities Act.
  - 5. NFPA 80, National Fire Protection Association
  - 6. NAAMM/HMMA, National Association of Architectural Metals Manufacturers.
  - 7. UL 10C, Standards for Positive Fire Tests of Door Assemblies.
- B. Manufacturer shall have been regularly engaged in manufacturing steel door, frames and window assemblies for a period of ten years. Doors and frames shall be fabricated by a single manufacturer. The manufacturer must have an effective quality control system in place.
- C. Provide current test reports to substantiate that all products have been tested to meet the following criteria.
  - 1. Fire Labeled doors and frames, ASTM E2074, UBC 7.2, UL 10C
  - 2. Performance test, ANSI A250.4
  - 3. Wind Load, Deflection / ASTM E330, Air Infiltration / ASTM E283, Water Penetration / ASTM E331
- D. Allowable Tolerances as stated in NAAMM/HMMA Technical Manual.

**1.03 SUBMITTALS:**

- A. Submittal Drawings: Show door and frame elevations and sections. Show listing of opening descriptions including locations, gages, and anchors. Show location and details of all openings. Include test reports on the following: Cycle test, Air and Water Infiltration.
- B. WARRANTY: All hollow metal work shall be warranted from defects in workmanship and quality for a period of one (1) year from shipment.

**PART II PRODUCTS**

**2.01 DOORS:**

- A. The Steel Doors are based on **StileLine™** a division of Stiles Custom Metal *"True Stile and Rail"* ([www.StileLine.com](http://www.StileLine.com)) and shall be of the types and sizes shown on the approved submittal drawings and shall be constructed in accordance with the specifications.
- B. Construction:
  - 1. Stile and Rail doors shall be unitized, true tube type construction with joints continuously welded and ground smooth.
  - 2. Door Core: Polystyrene, rigid, extruded, closed cell board, 1 pound per cubic foot density min., conforming to ASATM C578, Type 1 shall fill void in stile and rails. Core shall be laminated to the inside of the door skins with contact adhesive achieving 100% bond.
  - 3. Vertical Edges: Door face sheets shall be joined at center of vertical edges and continuously welded full height of the door with no visible seams on their faces or vertical edges. Welds shall be finished smooth. Single acting doors - beveled 1/8" in 2" profile. Double acting doors - rounded on 2-1/8" radius. All hardware furnished by the hardware contractor for single acting doors shall be designed for beveled edges as specified herein.

4. Integral Astragal: Where required astragals shall be formed as an integral part of the doors skin with corresponding recessed area formed into adjacent door. Surface mounted flat plate or Z shaped astragals shall not be accepted.
5. Door thickness shall be 1 3/4". Doors shall be neat in appearance and free from warpage or buckle. Edge bends shall be true and straight and of minimum radius for the gage of metal used.
6. Materials: Doors shall be made of commercial quality, cold-rolled steel per ASTM A1008 / A1008M. Stile and rails shall be 0.053 in. (16 gage) min. thickness with zinc coating A 60 at exterior..
7. The top and bottom edges shall be closed with a continuous channel, 16 gage minimum, spot welded to both face sheets maximum 4" o.c. Top of exterior doors shall be fitted with an additional flush closing channel and sealed water-tight.
8. Door opening tag number shall be permanently engraved into the center hinge reinforcement using a programmable engraver. The engraving shall be deep enough to be read after the hinge reinforcement bar is painted. The use of paper stickers only is not acceptable.
9. Glass moldings and stops: Where specified, Fixed molding stop shall be a formed integral of the door skin to secure glazing in accordance with glass sizes and thickness shown on approved submittal drawings. Removable glass channel stops shall be butted at corner joints, secured to the door with concealed, #8, sheet metal screws. Exposed fasteners shall not be accepted. Door lights that are cut out of the door after the door is built are not acceptable. Externally mounted lite kits that protrude from the door face are not acceptable.
10. Louvers: Louvers shall be sight proof, with [embossed, security type kick proof] or [V or Y type] blades, minimum 18 gage, secured to door with sheet metal screws. Louvers at exterior locations shall be A60 galvanized and be provided with Insect screens. Door skins at louver cutouts shall be reinforced with continuous channel reinforcement, full door thickness and perimeter, spot welded to door face 4" o.c.
11. Finish: After fabrication, all tool marks and surface imperfections shall be removed, and exposed faces of all welded joints shall be dressed smooth.

## **2.02 STEEL PANELS:**

- A. Steel panels shall be made of the same material and construction and finished in the same way as specified for doors.

## **2.03 FRAMES:**

- A. Provisions of this section are applicable to door frames, transom lights, sidelights and window assemblies.
  1. Materials: Frames shall be constructed of 16 gage, 0.053 in. (1.3mm) minimum thickness. Exterior frames shall have an A60 zinc coating.
  2. Construction: Frames shall be welded units of the sizes and types shown on approved shop drawings. Knocked-down frames shall not be accepted. Jamb, header; mullion and sill profiles shall be in accordance with the frame schedule and as shown on the approved submittal drawings.
  3. Mitered corner joints shall have all contact edges closed tight with faces mitered and stops butted. Faces and soffits shall be continuously welded. The use of gussets or splice plates shall not be acceptable. All other joints shall have faces continuously welded. Faces shall be finished smooth. Mineral fillers are not permitted.
  4. Exterior windows: Window installer and glazer shall follow Stiles instructions to prevent air and water penetration.
  5. Exterior door frames shall have "Seal-Tek" integral weather-strip kerf provided.
  6. When shipping limitations so dictate, frames for large openings shall be fabricated in sections designated for assembly in the field by installer. Field joints shall be made in accordance with approved submittal drawings and shall be field welded by installer.

## **2.04 FINISH HARDWARE:**

- A. Doors and frames shall be mortised, reinforced, drilled and tapped at the factory for completely templated mortised hardware only, in accordance with the final approved hardware schedule and templates provided by the hardware supplier. Where surface mounted, anchor hinges, or non-template

mortise hardware is to be applied, doors shall be reinforced, with all drilling and tapping done by others in the field. Reinforcement steel shall comply with NAAMM/HMMA 830 and 861.

## **2.05 FINISH:**

Doors and frames shall be treated to insure maximum paint adhesion and shall be painted on all accessible surfaces with one coat of a rust inhibitive, modified Alkyd, Zinc compound, gray primer that meets or exceeds all ANSI A250.10-98 performance criteria. Primer coat shall be fully cured prior to shipment. Red or brown colored primers shall not be permitted.

## **PART III EXECUTION**

**3.01 CLEARANCES AND TOLERANCES** shall be in compliance with NAAMM / HMMA standards.

### **3.02 SITE STORAGE AND PROTECTION OF MATERIALS**

- A. Deliver and store materials to prevent damaging and marring finishes.
- B. Protection: Protect metal surfaces from contact with lime, mortar, cement, acids, and other harmful surfaces and from careless handling, storage or machining.

### **3.03 INSTALLATION:**

- A. It shall be the responsibility of the installation contractor to perform the following:
- B. Installation and tolerances shall meet the requirements of HMMA 840 and as further specified here in. Prior to installation, all frames must be checked and corrected for size, swing, squareness, alignment, twist and plumbness.
- C. Any grout or other bonding material shall promptly be cleaned off of frames or doors following installation.  
Hollow metal surfaces shall be kept free of grout, tar, or other bonding material or sealer.
- D. Plaster guards and junction boxes are intended to protect hardware mortises and tapped mounting holes from masonry grout of 4" maximum slump consistency which is hand troweled in place. Grouting materials such as gypsum products which require air to dry (cure) shall not be used in any closed section, such as a mullion.
- E. Hardware must be applied in accordance with hardware manufacturer's templates and instructions.
- F. Primed or painted surfaces which have been scratched or otherwise marred during installation including field welding and/or cleaning shall be promptly finished smooth, cleaned, treated for maximum paint adhesion and touched up with a rust inhibitive primer.

END OF SECTION

**STAINLESS STEEL DOORS AND FRAMES  
SECTION 081130**

**PART I GENERAL**

**1.01 SUMMARY:**

- A. Description: This section includes interior and exterior Stainless Steel Doors and Frames, related sidelites, transoms lites and Windows where applicable.
- B. Related work not included in this section:
  - 1. Finish Hardware including lock cylinders and Thresholds.
  - 2. Glass and glazing.
  - 3. Caulking between frames and masonry
  - 4. Structural members

**1.02 QUALITY ASSURANCE:**

- A. Applicable standards of the following as referenced herein:
  - 1. AAMA, American Architectural Manufacturers Association.
  - 2. ASTM, American Society for Testing and Materials.
  - 3. ADA, Americans with Disabilities Act.
  - 4. NAAMM/HMMA, National Association of Architectural Metals Manufacturers.
- B. Quality is based on the products manufactured by **StileLine™** a division of Stiles Custom Metal ([www.StileLine.com](http://www.StileLine.com))
- C. Manufacturer shall have been regularly engaged in manufacturing bronze doors and frames for a period of ten years. Door and frame shall be fabricated by a single manufacturer. The manufacturer must have an effective quality control system in place.
- C. Allowable Tolerances as stated in NAAMM/HMMA Technical Manual.

**1.03 SUBMITTALS:**

- A. Shop drawings: Indicate in elevation with sections and details to scale. Include glass and metal thicknesses, joining details, field connections, anchorage, concealed and exposed fastening methods, door and framing reinforcement, and metal finishes. Indicate compliance with specified design criteria.
- B. Finish samples: Submit two (minimum 5" x 7") samples indicating texture to be expected of finished work.
- C. Maintenance data: Give instructions for general maintenance and repair of surfaces and finishes.

**1.04 WARRANTY:** Warrant Stainless Steel Doors, Frame and Window assemblies against defect in materials and workmanship for three (3) years from date of shipment when handled, stored, and installed in accordance with manufactures instruction and NAAMM/HMMA Technical Manual. Adjustments made necessary by shifting or settling of building structure shall not be covered by warranty. Clear coat manufacturer's warranty applies.

**PART II PRODUCTS**

**2.01 DOORS:**

- A. Acceptable Stainless Steel Door products as manufactured by **StileLine™** a division of Stiles Custom Metal ([www.StileLine.com](http://www.StileLine.com))
- B. Stainless Steel Materials: (choose one) AISI Type [304], 316] or [430].
  - 1. Frames: (choose one) [0.060" 16 gauge] or [0.072" 14 gauge].
  - 2. Doors: (choose one) [0.060" 16 gauge] or [0.072" 14 gauge].
- C. Finish Texture: (Choose one) [#4 satin], [#8 polished], [non-directional], [angel-hair], [bead blasted], [random swirl] other finishes and embossing also available.
- D. Design of stile and rail profiles: As indicated on drawings. Door thickness (choose one) [1-3/4"] or [2"]. Code may stipulate bottom rail height.
- E. Door Construction: Doors shall be unitized construction with continuous forms reinforcement stiffening channels welded into door body. Hardware reinforcement: seven gauge at hinges, eleven gauge at lock/latch preparations welded into door body.
  - 1. Stile and rail doors shall be blanked out from one sheet of metal. No welding shall be performed on door faces. Exposed seams on door faces or edges are not acceptable. Fabrication with bolt, screw or tie rod connections are not acceptable.

2. Door edge construction (choose one) [Stiles replaceable Air-Tek integral weather-strip] [Hairline seam] [Continuous Welded Seamless]. Adhesive or screw applied weather strip shall not be accepted.
  3. Stainless Steel cladding over aluminum, steel or wood constructed shall not be accepted.
- F. Glass Lite Kits: (choose one)
- [Molding type lite kit with mitered corners welded, finished smooth and re-grained to match. Exterior side of door to be concealed welded. Interior side to include #8 oval head sheet metal screws].
  - [Internal channel type, flush glass moldings, securely welded to the inside face of the door skin. Removable glass channel stops shall be butted at corner joints, secured to the door with concealed, #8, sheet metal screws. Exposed fasteners shall not be accepted].

## **2.02 FRAMES:**

- A. Construction:
1. Stainless Steel Materials: (choose one) AISI Type [304], [316] or [430].
  2. Stainless Steel thickness: (choose one) [0.060" 16 gauge] or [0.072" 14 gauge].
  3. Frames shall be welded units of the sizes and types shown on approved shop drawings. Knocked-down frames shall not be accepted. Jamb, header, mullion and sill profiles shall be in accordance with the frame schedule and as shown on the approved submittal drawings. All welds shall be finished smooth and regained to match.
  4. Windows shall be provided with fixed and removable stops. Loose stops shall be channel type with butted corners and attached with counter sunk, oval head, stainless steel, sheet metal screws.
- B. Fasteners shall be stainless steel. Exposed fasteners shall be countersunk and shall match entrances and framing in color.
- C. Exterior door frames shall have "Seal-Tek" integral weather-strip at vertical jambs and head. For details see [www.StileLine.com](http://www.StileLine.com)

## **2.03 FINISH HARDWARE:**

1. Doors and frames shall be mortised, reinforced, drilled and tapped at the factory for completely templated mortised hardware only, in accordance with the final approved hardware schedule and templates provided by the hardware supplier. Where surface mounted, anchor hinges, or non template, mortised hardware is to be applied, doors shall be reinforced, with all drilling and tapping done by others in the field. Reinforcement steel shall comply with NAAMM/HMMA 830 and 861.

## **PART III EXECUTION**

**3.01 CLEARANCES AND TOLERANCES** shall be in compliance with NAAMM / HMMA standards.

### **3.02 SITE STORAGE AND PROTECTION OF MATERIALS**

- A. Deliver and store materials to prevent damaging and marring finishes.
- B. Protection: Protect metal surfaces from contact with lime, mortar, cement, acids, and other harmful surfaces and from careless handling, storage or machining.

### **3.03 INSTALLATION:**

- A. Framing systems shall be installed per **StileLine™** instructions and NAAMM / HMMA 840. Install frames without use of exposed fasteners, except where indicated on shop drawings.
- B. Door Installation: Install doors and hardware in accordance with manufacturer's product data. Adjust hardware for proper operation. Adjust door closers for smooth operation throughout swing.

**3.04 CLEANING:** Clean doors and frames in accordance with manufacturer's special instructions.

**3.05 MAINTENANCE:** Instruct the Owner's Maintenance Personnel regarding the operation and maintenance of these doors.

END OF SECTION

**AUTHENTIC BRONZE DOORS AND FRAMES  
SECTION 081140**

**PART I GENERAL**

**1.01 SUMMARY:**

- A. Description: Work includes Bronze Interior and Exterior Doors and Frames, related Sidelites and Transoms where applicable.
- B. Related work not included in this section:
  - 1. Finish Hardware including Lock cylinders and Thresholds.
  - 2. Glass and glazing.
  - 3. Lock cylinders
  - 4. Caulking between frames and masonry
  - 5. Structural members

**1.02 QUALITY ASSURANCE:**

- A. Applicable standards of the following as referenced herein:
  - 1. AAMA, American Architectural Manufacturers Association.
  - 2. ASTM, American Society for Testing and Materials.
  - 3. ADA, Americans with Disabilities Act.
  - 4. CDA, Copper Development Association.
  - 5. NAAMM/HMMA, National Association of Architectural Metals Manufacturers
- B. Quality is based on the Authentic Bronze Doors and Frames manufactured by **StileLine™** a division of Stiles Custom Metal ([www.StileLine.com](http://www.StileLine.com))
- C. Manufacturer shall have been regularly engaged in manufacturing bronze doors and frames for a period of ten years. Door and frame shall be fabricated by a single manufacturer. The manufacturer must have an effective quality control system in place.
- D. Allowable Tolerances as stated in NAAMM/HMMA Technical Manual.

**1.03 SUBMITTALS:**

- A. Shop drawings: Indicate in elevation with sections and details to scale. Include glass and metal thicknesses, joining details, field connections, anchorage, concealed and exposed fastening methods, door and framing reinforcement, and metal finishes. Indicate compliance with specified design criteria.
- B. Finish samples: Submit two (minimum 5" x 7") samples indicating texture and color and to be expected of finished work.
- C. Maintenance data: Give instructions for general maintenance and repair of surfaces and finishes.

**1.04 WARRANTY:**

- A. Warrant Bronze Doors, Frame and Window assemblies against defect in materials and workmanship for three years beginning thirty days after shipment when handled, stored, and installed in accordance with manufactures instruction and NAAMM/HMMA Technical Manual. Adjustments made necessary by shifting or settling of building structure shall not be covered by warranty. Clear coat manufacturer's warranty applies.

**PART II PRODUCTS**

**2.01 DOORS:**

- A. Acceptable products: **StileLine™** a division of Stiles Custom Metal, Inc., Authentic Bronze Doors and Frames ([www.StileLine.com](http://www.StileLine.com)).
- B. Bronze Materials: CDA Alloy 464 Naval Brass, Doors minimum 0.06" thick.
- C. Finish : [Choose one]
  - 1. Texture: (Choose one) [#4 satin], [#8 polished], [non-directional] [angel hair] [random swirl].
  - 2. Color: (Choose one) [Natural] [Medium bronze] [Oil rubbed bronze] [Dark statuary bronze].
  - 3. Clear protective lacquer coating: (Choose one) [No clear coat required] [Satin], [Semi gloss] [High gloss].
- D. Fasteners: Bronze fasteners associated with door construction shall be concealed type.

- E. Design of stile and rail profiles: As indicated on drawings. Door thickness (choose one) [1-3/4"] or [2"]. Code may stipulate bottom rail height.
- F. Door Construction: Doors shall be unitized construction with continuous forms reinforcement stiffening channels welded into door body. Three metal thicknesses, welded into door body shall be required for all hardware reinforcement.
  - 1. Stile and rail doors shall be blanked out from one sheet of metal. No welding shall be performed on door faces. Exposed seams on door faces are not acceptable. Assemble with bolt, screw or tie rod connections are not acceptable.
  - 2. Doors to have high impact resistant polyurethane core.
  - 3. Door edge construction (Choose one) [Stiles replaceable Air-Tek integral weather-strip] [Hairline seam] [Continuous Welded Seamless]. Adhesive or screw applied weather strip shall not be accepted.
  - 4. Cladding over aluminum, steel or wood construction shall not be accepted.
- G. Glass Lite Kits: (Choose one)
  - 1. [Molding type lite kit with mitered corners welded, finished smooth and re-grained to match. Molding on exterior side of door to be permanently attached. Interior removable molding shall be attached with #8 oval head sheet metal screws of matching material].
  - 2. [Internal channel type, flush glass moldings, securely welded to the inside face of the door skin. Removable glass channel stops shall be butted at corner joints, secured to the door with concealed, #8, sheet metal screws. Exposed fasteners shall not be accepted].

## 2.02 FRAMES:

- A. Construction:
  - 1. Material shall be minimum 0.08" thick with the same texture and finish as doors.
  - 2. Fabricate components in accordance with approved shop drawings. Frames shall be fully welded construction with welds ground smooth and blended to be indistinguishable in finished work. Finish to matching entrance doors.
- B. Exposed fasteners shall be countersunk and match framing color.
- C. Exterior Door frames shall have Stiles replaceable "Seal-Tek" integral weather-strip at vertical jambs and head. Adhesive applied weather strip shall not be accepted.
- D. Hardware: Manufacturer shall prepare and reinforce for mortised template hardware per manufacturer templates and in accordance with NAAMM/HMMA.

## PART III EXECUTION

**3.01 CLEARANCES AND TOLERANCES** shall be in compliance with NAAMM / HMMA standards.

### 3.02 SITE STORAGE AND PROTECTION OF MATERIALS

- A. Deliver and store materials to prevent damaging and marring finishes.
- B. Protection: Protect metal surfaces from contact with lime, mortar, cement, acids, and other harmful surfaces and from careless handling, storage or machining.

### 3.03 INSTALLATION:

Framing systems shall be installed per **StileLine™** instructions and NAAMM / HMMA 840. Install frames without Use of exposed fasteners, except where indicated on shop drawings.

- A. Door Installation: Install doors and hardware in accordance with manufacturer's product data. Adjust hardware for proper operation.

**3.04 CLEANING:** Clean doors and frames in accordance with manufacturer's special instructions.

**3.05 MAINTENANCE:** Instruct the Owner's Maintenance Personnel regarding the operation and maintenance of these doors.

END OF SECTION



## BRONZE CLAD STEEL DOORS AND FRAMES SECTION 081140

### PART I GENERAL

#### 1.01 SUMMARY:

- A. Description: Work includes Bronze Clad Interior and Exterior Steel Doors and Frames, related Sidelites and Transoms where applicable.
- B. Related work not included in this section:
  - 1. Finish Hardware including Lock cylinders and Thresholds.
  - 2. Glass and glazing.
  - 3. Lock cylinders
  - 4. Caulking between frames and masonry
  - 5. Structural members

#### 1.02 QUALITY ASSURANCE:

- A. Applicable standards of the following as referenced herein:
  - 1. AAMA, American Architectural Manufacturers Association.
  - 2. ASTM, American Society for Testing and Materials.
  - 3. ADA, Americans with Disabilities Act.
  - 4. CDA, Copper Development Association.
  - 5. NAAMM/HMMA, National Association of Architectural Metals Manufacturers
- B. Quality is based on the Bronze Clad Steel Doors and Frames manufactured by **StileLine™** a division of Stiles Custom Metal, Inc., ([www.StileLine.com](http://www.StileLine.com))
- C. Manufacturer shall have been regularly engaged in manufacturing bronze doors and frames for a period of ten years. Door and frame shall be fabricated by a single manufacturer. The manufacturer must have an effective quality control system in place.
- D. Allowable Tolerances as stated in NAAMM/HMMA Technical Manual.

#### 1.03 SUBMITTALS:

- A. Shop drawings: Indicate in elevation with sections and details to scale. Include glass and metal thicknesses, joining details, field connections, anchorage, concealed and exposed fastening methods, door and framing reinforcement, and metal finishes. Indicate compliance with specified design criteria.
- B. Finish samples: Submit two (minimum 5" x 7") samples indicating texture and color and to be expected of finished work.
- C. Maintenance data: Give instructions for general maintenance and repair of surfaces and finishes.

#### 1.04 WARRANTY:

- A. Warrant Bronze Doors, Frame and Window assemblies against defect in materials and workmanship for three years beginning thirty days after shipment when handled, stored, and installed in accordance with manufactures instruction and NAAMM/HMMA Technical Manual. Adjustments made necessary by shifting or settling of building structure shall not be covered by warranty. Clear coat manufacturers warranty applies.

### PART II PRODUCTS

#### 2.01 DOORS:

- A. Acceptable products: **StileLine™** a division of Stiles Custom Metal, Inc., Authentic Bronze Doors and Frames ([www.StileLine.com](http://www.StileLine.com)).
- B. Bronze Cladding Material: CDA Alloy 464 Naval Brass, minimum 0.045" thick.
- C. Finish : [choose one]
  - 1. Texture: (choose one) [#4 satin], [#8 polished], [non-directional] [angel hair] [random swirl].
  - 2. Color: (choose one) [Natural] [Medium bronze] [Oil rubbed bronze] [Dark statuary bronze].
  - 3. Clear protective lacquer coating: (choose one) [No clear coat required] [Satin], [Semi gloss] [High gloss].
- D. Design of stile and rail profiles: As indicated on drawings. Door thickness (choose one) [1-3/4"] or [2"]. Code may stipulate bottom rail height.

- E. Door Construction:
1. Base steel doors minimum 0.056" thickness and shall be unitized construction with continuous forms reinforcement stiffening channels welded into door body consistent with Stiles steel door construction.  
Assemble with bolt, screw or tie rod connections are not acceptable.
  2. Bronze Cladding: Minimum 0.045" thick. Cladding shall be blanked out from one sheet of metal. No welding shall be permitted. Exposed seams on door faces are not acceptable. Prior to cladding base door shall have a permanent coating applied which will prevent galvanic reaction. Cladding shall be applied to door with a tested, permanent, life time compression adhesive.
  3. Door edge construction (Choose one) [Stiles replaceable Air-Tek integral weather-strip] [Hairline seam]. Adhesive or screw applied weather strip shall not be accepted.
  4. Cladding over aluminum, steel or wood construction shall not be accepted.
- F. Glass Lite Kits: (Choose one)
- [Molding type lite kit with mitered corners welded, finished smooth and re-grained to match. Molding on exterior side of door to be permanently attached. Interior removable molding shall be attached with #8 oval head sheet metal screws of matching material].
  - [Internal channel type, flush glass moldings, securely welded to the inside face of the door skin. Removable glass channel stops shall be butted at corner joints, secured to the door with concealed, #8, sheet metal screws. Exposed fasteners shall not be accepted].

## 2.02 FRAMES:

- A. Construction:
1. Material shall be minimum 0.08" thick with the same texture and finish as doors.
  2. Fabricate components in accordance with approved shop drawings. Frames shall be fully welded construction with welds ground smooth and blended to be indistinguishable in finished work. Finish to matching entrance doors.
- B. Exposed fasteners shall be countersunk and match framing color.
- C. Exterior Door frames shall have Stiles replaceable "Seal-Tek" integral weather-strip at vertical jambs and head. Adhesive applied weather strip shall not be accepted.
- D. Hardware: Manufacturer shall prepare and reinforce for mortised templated hardware per manufacturer templates and in accordance with NAAMM/HMMA.

## PART III EXECUTION

**3.01 CLEARANCES AND TOLERANCES** shall be in compliance with NAAMM / HMMA standards.

### 3.02 SITE STORAGE AND PROTECTION OF MATERIALS

- A. Deliver and store materials to prevent damaging and marring finishes.
- B. Protection: Protect metal surfaces from contact with lime, mortar, cement, acids, and other harmful surfaces and from careless handling, storage or machining.

### 3.03 INSTALLATION:

- A. Framing systems shall be installed per **StileLine™** instructions and NAAMM / HMMA 840. Install frames without use of exposed fasteners, except where indicated on shop drawings.
- B. Door Installation: Install doors and hardware in accordance with manufacturer's product data. Adjust hardware for proper operation.

### 3.04 CLEANING:

- A. Clean doors and frames in accordance with manufacturer's special instructions.

### 3.05 MAINTENANCE:

- A. Instruct the Owner's Maintenance Personnel regarding the operation and maintenance of these doors.

END OF SECTION